

AMMETER EPM-34

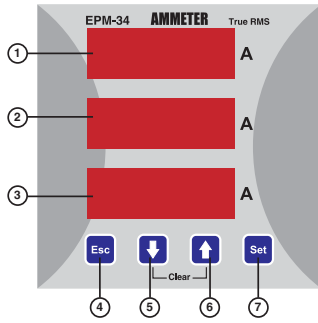

- 1 Display of IL1 input.
- 2 Display of IL2 input.
- 3 Display of IL3 input.
- 4 ESC button to exit from a menu any time.
- 5 DOWN button.
- 6 UP button.
- 7 SET button. It is used to enter into the menu and to save the values. If SET button is pressed for 3 seconds in the measurement mode, you can enter into menus.

PRECAUTIONS FOR INSTALLATION AND SAFE USE

- Failure to follow those instructions will result in death or serious injury.
- Disconnect all power before working on equipment.
- When the device connected to the network, do not remove the front panel.
- Do not try to clean the device with solvent or the like. Only clean the device with dried cloth.
- Verify correct terminal connections when wiring.
- Electrical equipment should be serviced only by your component seller.
- Only for rack panel mounting.
- The fuse should be used F type and current boundary value must be 6A.
- No responsibility is assured by manufacturer or any of its subsidiaries for any consequences arising out of the use of this material.

General Information

EPM-34 is designed to measure the phase currents in 3 phase systems.

Applications of EPM-34

- 1) It can measure Phase Currents (IL) in 3 phase systems.
- 2) You can observe demand and max. demand values of measured currents with 2 different periods, also the calculation time for demand and max. demand values can be determined from the dE-t (demand time) menu.
- 3) Current transformer ratio can be programmed, [1.....1000 (for X/5A), 1.....5000 (for X/1A)]
- 4) A password can be arranged from **PASS CodE** menu in order to prevent change of the setting by unauthorized person.

Specific Functions of Buttons:

While device is in the measurement mode, some buttons and button groups have below special functions.

- : When "DOWN" button is pressed, 1st demand values are displayed.
- : When "UP" button is pressed, 1st max. demand values are displayed.
- : When "ESC" and "DOWN" buttons are pressed at the same time, 2nd demand values are displayed.
- : When "ESC" and "UP" buttons are pressed at the same time, 2nd max. demand values are displayed.
- : When "DOWN" and "UP" buttons are pressed at the same time, all demand and max. demand values are reset.

EPM-34 Menu Settings

After making the connections of the device as given in user manual, voltage is supplied. Required settings must be done by using menus in order to have the correct measurements and applications.

Current Transformer Menu

In this menu, current transformer ratio and current transformer secondary value is set.

Current Transformer Ratio

In this menu, current transformer ratio is set.

[1 1000 (for X/5A), 1 5000 (for X/1A)]

Note: If the current transformer is not used between the system and EPM-34, CT ratio must be set as "1".

For example: If a current transformer with 30 A / 5 A is used between the system and EPM-34, CT ratio must be set as "6". (30/5=6)

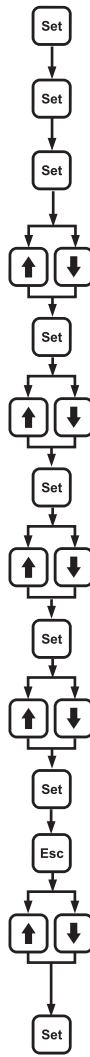

In order to set CT ratio. In the measurement mode; Press SET button for 3 secs.(CUR- rEnt trF menu is displayed)

Press SET button (Ctr menu is displayed)

Press SET button (1st digit of second display blinks)

Find 1st digit of the value which you want to enter by scrolling UP/DOWN buttons.

Press SET button (2nd digit of second display blinks. If you set 1st digit value incorrect, you can set again by pressing ESC button)

Find 2nd digit value by scrolling UP/DOWN buttons.

Press SET button (3rd digit of second display blinks. If you set 2nd digit value incorrect, you can set again by pressing ESC button.)

Find 3rd digit value by scrolling UP/DOWN buttons.

Press SET button (4th digit of second display blinks. If you set 3rd digit value incorrect, you can set again by pressing ESC button.)

Find 4th digit value by scrolling UP/DOWN buttons.

Press SET button (Ctr is displayed.)

Press ESC button one by one until SAUE SET no is displayed.

By using UP/DOWN buttons, find SAUE SET yES

Press SET button while SAUE SET yES is displayed. (If you press ESC button or select "no" option instead of "yES", new data is cancelled and the previous data is set.)



Current transformer secondary value setting

In this menu, current transformer secondary value can be set as "5A" or "1A".

Note: If the secondary value is changed from "5A" to "1A", Ctr (current transformer ratio) value is set as 5 times of previous value automatically. If the secondary value is changed from "1A" to "5A", Ctr (CT ratio) value is set as 1/5 times of the previous value automatically.

In order to set secondary value; in the measurement mode, Press SET button for 3 secs.(CUR- rEnt trF menu is displayed)

Press SET button (Ctr menu is displayed.)

By using UP/DOWN buttons, find SEC menu.

Press SET button (activesecondary value is displayed on second display)

Set the secondary current value by using UP/DOWN buttons

Press SET button SEC is displayed. (New value is entered but it is not executed yet. In order to set the new value, please follow below steps)

Press ESC button one by one until SAUE SET no is displayed.

By using UP/DOWN buttons, find "SAUE SET yES"

Press SET button while SAUE SET yES is displayed. (If you press ESC button or select "no" option instead of "yES", new data is cancelled and the previous data is set.)

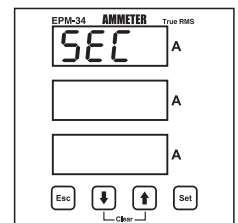
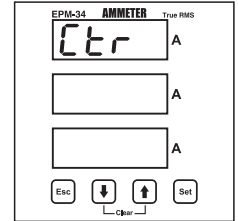

AMMETER EPM-34

dE-t (Demand Time - Demand calculation time) Menu:

dE-1 (1st Demand Time - 1st Demand calculation time) Menu

dE-1 demand time can be set between 1-60 minutes which is independent from dE-2. In this time interval, 1st demand and 1st max. demand values are calculated.

dE-2 (2nd Demand Time - 2nd Demand calculation time) Menu

dE-2 demand time can be set between 1-60 seconds which is independent from dE-1. In this time interval, 2nd demand and 2nd max. demand values are calculated.

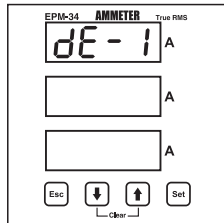
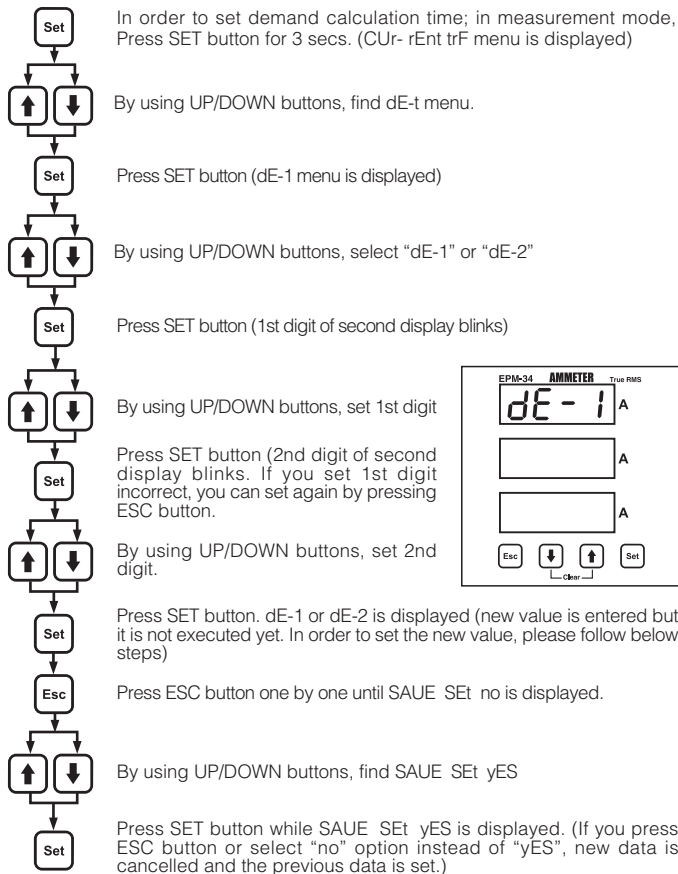

PASS Code Enbl User Password Settings

User password is set and activated in this menu. In order to prevent the device's settings from unauthorized access, it is necessary to set up a 4 digits user password and then activate it.

This menu has 2 submenus.

Changing the User Password

In this menu, user password can be changed.

Note: Factory set value for user password is "1234"

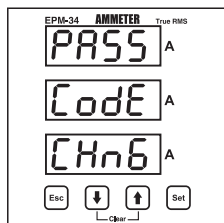
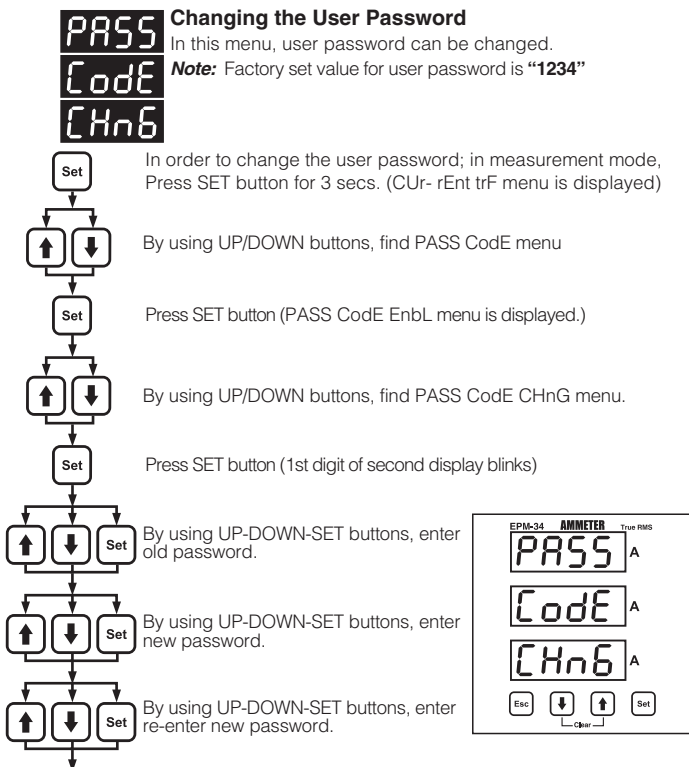

Press SET button PASS CodE CHnG is displayed. (New value is entered but is not executed yet. In order to set the new value, please follow below steps.)

Press ESC button one by one until SAUE SET no is displayed.

By using UP/DOWN buttons, find SAUE SET yES

Press SET button while SAUE SET yES is displayed. (If you press ESC button or select "no" option instead of "yES", new data is cancelled and the previous data is set.)

PASS Code Enbl Activating the user password

This menu is used to activate the user password.

After activating the user password, if SET button is pressed for 3 seconds in order to enter to the menu, a user password is required.

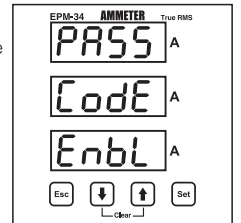
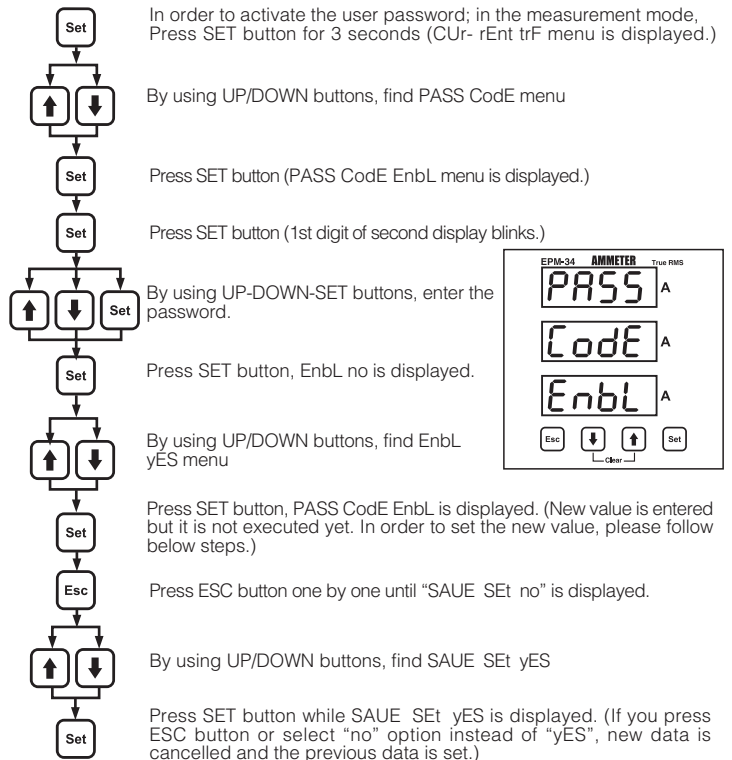

Technical Features

Operating Voltage (Un)	: 24 ... 250 V AC/DC
Frequency (Hz)	: 45-65 Hz
Auxiliary Supply Power Consumption	: < 4 VA
Measurement input power consumption	: < 1VA
lin	: 0.005-5.5A~ (for X/5A) 0.005-1.1A~ (for X/1A)
Class	: %0.5±1digit [(%10-%110) x full scale]
Current Transformer Ratio	: 1 ... 1000 (for X/5A) 1 ... 5000 (for X/1A)
Ambient Temperature	: -5°C; +70°C
Display	: Red LED display
Dimension	: PR-19
Equipment Protection Class	: Double Insulation-Class II (□)
Box Protection Class	: IP 54
Terminal Protection Class	: IP 00
Box Material	: Non-flammable
Installation	: Panel Mounted
Wire thickness for terminal connection	: 4 mm ²
Weight	: 0.34 kg
Installation Category	: Class III
Panel Cut-outs	: 91x91mm
Complies with EN-61010-1 standard.	

Dimensions

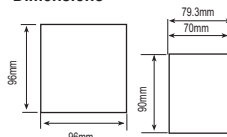

Connection Diagram

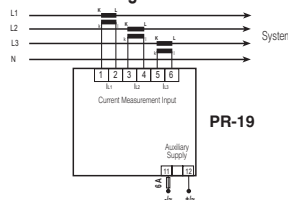

Panel Cut-outs

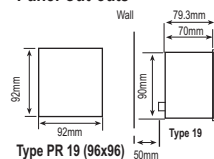

Factory Set Values

Ctrl - 0001
SEC - 5A
dt1 - 15
dt2 - 30
PASS CodE Enbl - no
PASS CodE - 1234

